

BRX

HOMEQUIP
QUALITY & SERVICE

DROP-IN

DROP IN COLLECTION

Indice Index

- pag. 02 **LA GAMMA BRX**
BRX SELECTION
- pag. 04 **I NOSTRI PRODOTTI LE LORO FUNZIONI**
OUR PRODUCTS THEIR FUNCTIONS
- pag. 06 **LE CORNICI**
THE FRAMES
- pag. 08 **ACCESSORI PER CORNICI**
ACCESSORIES FOR FRAMES
- pag. 10 **DUAL**
- pag. 26 **MISURE, COMPONIBILITÀ**
DIMENSIONS, MODULARITY
- pag. 28 **NEA**
- pag. 34 **MISURE, COMPONIBILITÀ**
DIMENSIONS, MODULARITY
- pag. 36 **P60 P80**
- pag. 44 **MISURE, COMPONIBILITÀ**
DIMENSIONS, MODULARITY
- pag. 48 **P60 BT - COCKTAIL STATION**
- pag. 52 **MISURE, COMPONIBILITÀ**
DIMENSIONS, MODULARITY
- pag. 54 **FRUTTINI**
- pag. 58 **MISURE, COMPONIBILITÀ**
DIMENSIONS, MODULARITY

DROP IN LA GAMMA

BRX SELECTION



DUAL

Visibilità e flessibilità progettuale: bassa temperatura, freddo ventilato e pralineria, doppio impianto freddo ventilato/caldo secco, caldo secco

Visibility and design flexibility:
cold ventilated and for chocolates,
double system cold ventilated/dry hot,
dry hot, low temperature



NEA

L'eleganza e la funzionalità della pasticceria canalizzabile: freddo ventilato e pralineria, doppio impianto freddo ventilato/caldo secco, caldo secco, neutro

The elegance and functionality of ductable pastry:
cold ventilated and for chocolates, double system cold
ventilated/dry hot , dry hot, neutral

Costruire una Drop-in, richiede molto più che tecnologie all'avanguardia e idee innovative. È il risultato di una filosofia tuttora valida e che perseguiamo con coerenza: prestazione e risparmio energetico. Da decenni lavoriamo per equipaggiare sempre meglio i modelli, per garantire la massima durata ed affidabilità.

The construction of a Drop-in, requires much more than cutting-edge technologies and innovative ideas. It's a result of a strong philosophy that we consistently pursue: performance and energy saving. For decades, we've been working to improve our models, to guarantee a long-lasting efficiency and reliability.

P60 - P80

bassa temperatura, freddo statico e ventilato doppio
impianto freddo ventilato/caldo, secco caldo secco e
bagnomaria,

cold static and ventilated, double system
cold ventilated/dry hot, dry hot and bain-marie,
low temperature



FRUTTINI

Piccole e versatili:
calde, fredde, neutre e su misura

Small and versatile:
hot, cold, neutral and tailor-made



DROP IN

LE FUNZIONI

THE FUNCTIONS

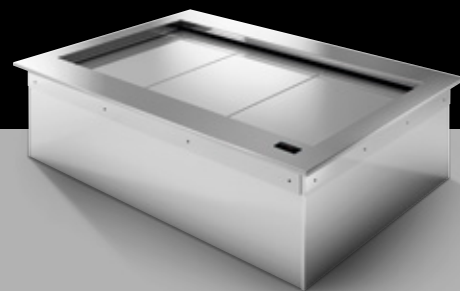

- DISPONIBILE
AVAILABLE
- NON DISPONIBILE
NOT AVAILABLE

VASCA FREDDO STATICO
COLD STATIC TUB

PIANO FREDDO STATICO A CONTATTO
COLD STATIC TOP BY CONTACT

VASCA FREDDO VENTILATO
COLD VENTILATED TUB

VASCA FREDDO VENTILATO / CALDO SECCO
COLD VENTILATED / DRY HOT TUB

VASCA CALDO SECCO
DRY HOT TUB

PIANO CALDO SECCO
DRY HOT TOP

PIANO CALDO SECCO IN VETRO
DRY HOT TOP IN GLASS

VASCA BAGNO MARIA
BAIN-MARIE TUB

VASCA BT / GELATERIA
LOW TEMPERATURE / ICE-CREAM TUB

VASCA COCKTAIL
COCKTAIL TUB

VASCA PRALINERIA / PASTICCERIA
CHOCOLATES / PASTRY TUB

VASCA NEUTRA
NEUTRAL TUB

VASCA NEUTRA COIBENTATA
INSULATED NEUTRAL TUB

DUAL



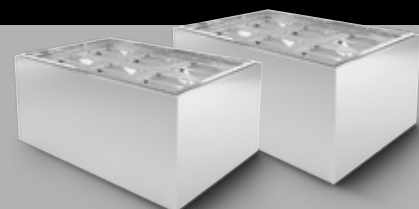
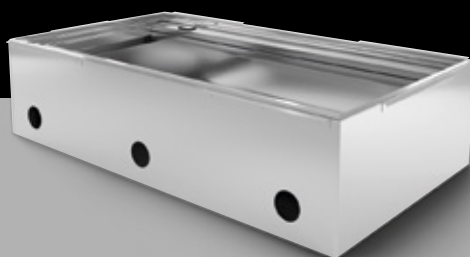
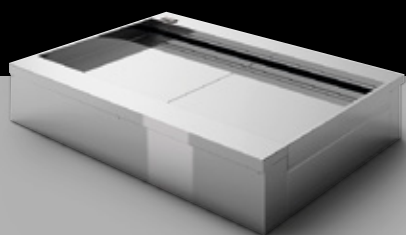

NEA

P60

P80

FRUTTINI

—	●	●	●
—	●	●	—
●	●	●	—
●	●	●	—
—	—	—	●
●	●	●	—
—	●	●	—
—	●	—	—
—	●	—	—
—	●	—	—
●	—	—	—
●	—	—	●
—	—	—	●

DROP IN LE CORNICI

THE FRAMES

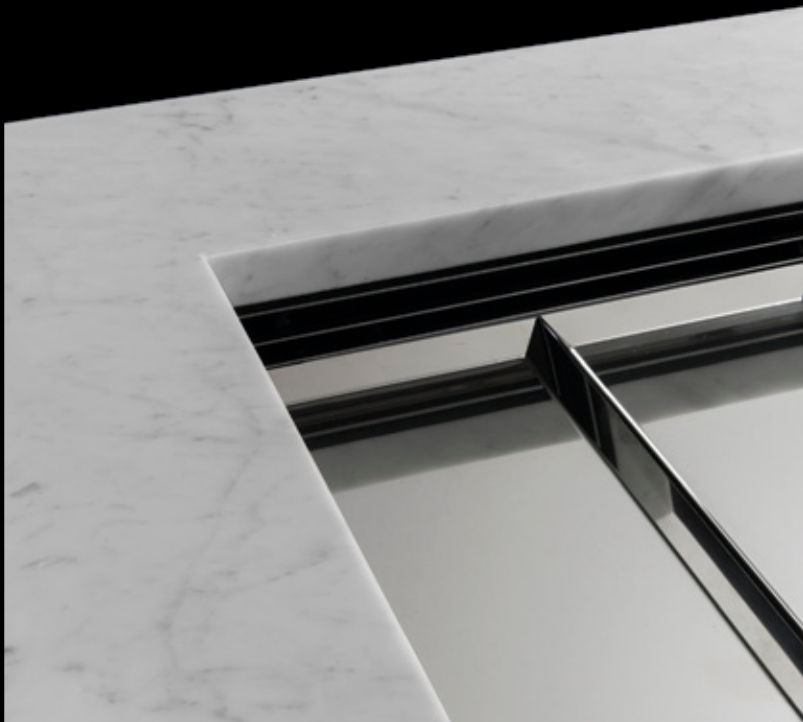

SOTTOTOP

Per evidenziare la bellezza del materiale utilizzato in tutto il suo spessore.

UNDERMOUNT

To enhance the beauty of the material used, and its total thickness.



SMALL

Elegante e minimale
rfinisce il bordo del top

SMALL

Elegant and minimal,
it finishes the working top edge



STEP

Elegante e minimale sul piano, la speciale conformazione della cornice permette l'appoggio dei moduli Gastronorm e l'inserimento di pianetti di appoggio o di copertura

STEP

elegant and minimal on the working top, the special structure of the frame allows to rest Gastronorm modules and to insert top and closing surfaces.



DROP

La cornice drop viene fornita già collegata per l'inserimento della vasca dall'alto. La sua conformazione permette l'appoggio dei moduli GN e l'inserimento di pianetti di appoggio o di copertura

DROP

It's supplied already connected to insert the tub from the top. Its structure allows to rest Gastronorm modules and to insert top and closing surfaces.

DROP IN

ACCESSORI PER CORNICI

ACCESSORIES FOR FRAMES



STEP



DROP

La speciale conformazione della cornice STEP e DROP permette l'appoggio dei moduli Gastronorm e l'inserimento di pianetti di appoggio o di copertura.

The special structure of STEP and DROP frames allows to rest Gastronorm modules and to insert top and closing surfaces.



COPERCHIO INOX
STAINLESS STEEL COVER



TAGLIERE IN
MATERIALE SINTETICO
CUTTING BOARD
IN SYNTHETIC MATERIAL





DROP IN

DUAL
UNA VASCA
MILLE
FUNZIONI

DUAL, ONE TUB ONE THOUSAND FUNCTIONS

IL PROGETTO DUAL PERMETTE DI ALLESTIRE UN BANCO CON TUTTE LE FUNZIONI PERFETTAMENTE ALLINEATE: GELATERIA, PASTICCERIA, PRALINERIA E GASTRONOMIA.

DUAL CONCEPT ALLOWS TO SET UP A COUNTER WITH ALL FUCTIONS, PERFECTLY ALIGNED: ICE-CREAM, PASTRY, CHOCOLATES AND GASTRONOMY.



Freddo Ventilato
e Doppia Funzione
Alta visibilità
mantenendo
una funzionalità
ottimale.

Cold ventilated
and double function
High visibility keeping
the best functionality.



DUAL



DUAL È L'IDEALE PER PROGETTARE BANCHI ESPOSITIVI MODERNI DI GRANDE VISIBILITÀ ED ESPORRE UN'INFINITÀ DI PRODOTTI ALLA TEMPERATURA IDEALE.

DUAL IS IDEAL TO DESIGN MODERN DISPLAY COUNTERS WITH TOTAL VISIBILITY, AND TO EXHIBIT LOTS OF PRODUCTS AT THE IDEAL TEMPERATURE.



DUAL

LA SPECIALE
CONFORMAZIONE
DELLA CORNICE
PERMETTE
UN UTILIZZO
DIFFERENTE NEL
CORSO DELLA
GIORNATA.

THE SPECIAL
FRAME'S
STRUCTURE ALLOWS
TO USE THE TUB IN
DIFFERENT WAYS
DURING THE DAY.

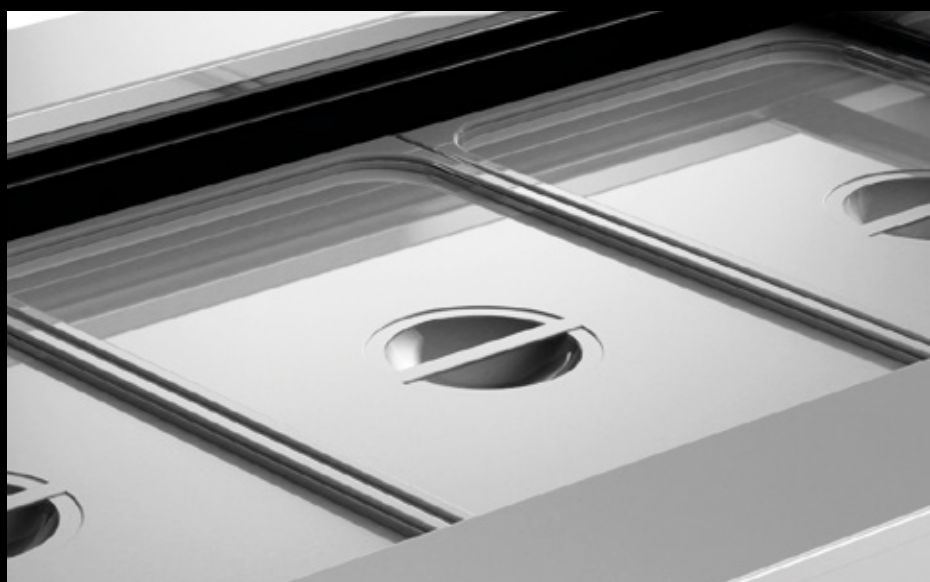

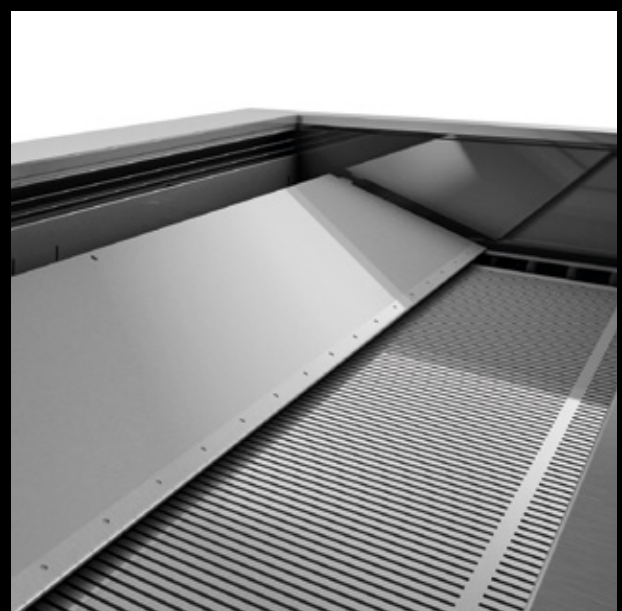
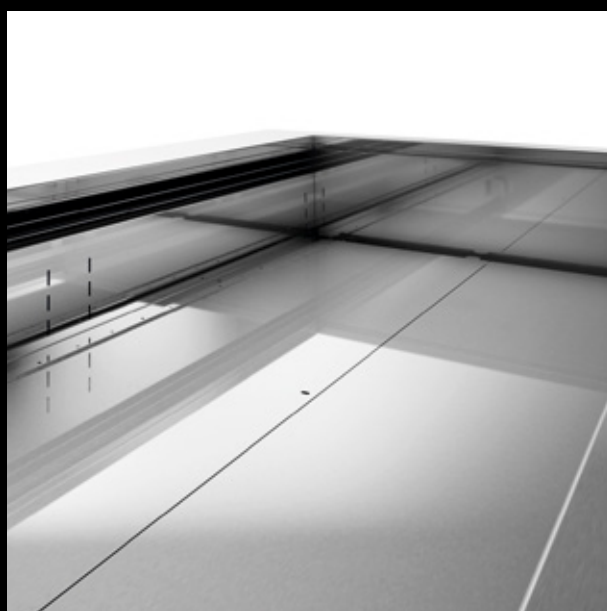

DUAL

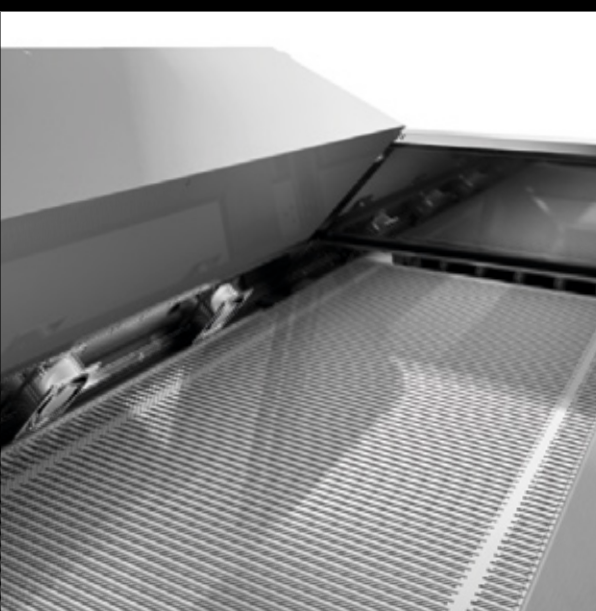
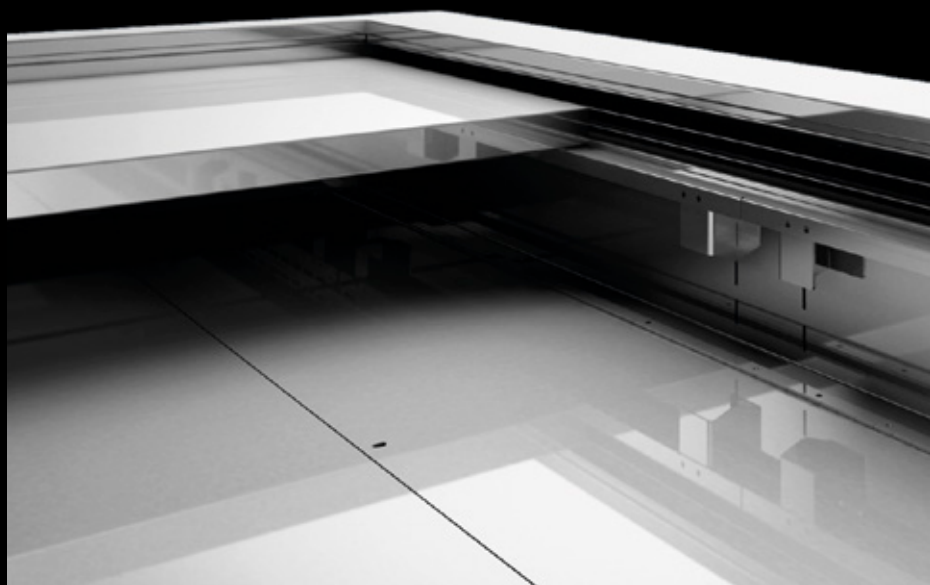
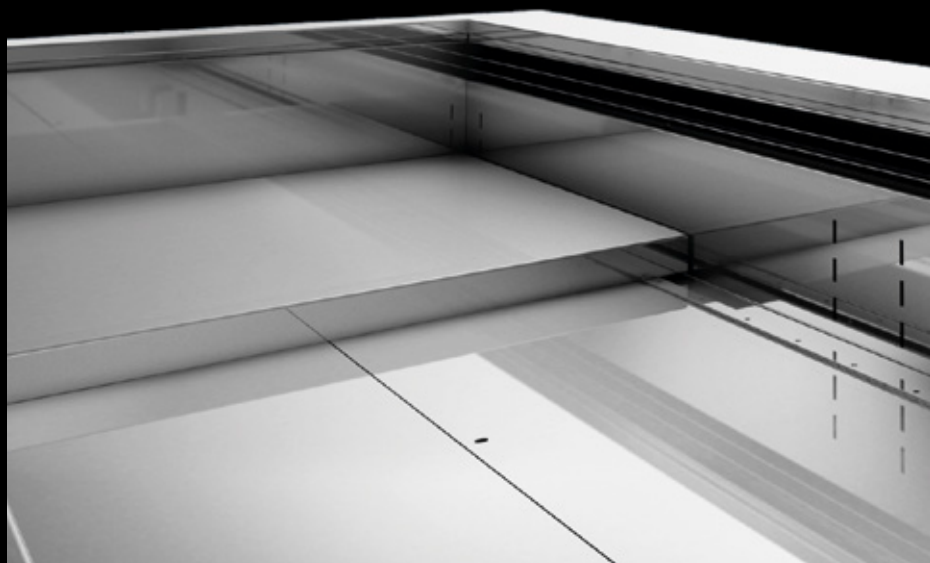

PIANO ESPOSITIVO REGOLABILE
IN 4 POSIZIONI

ADJUSTABLE DISPLAY SURFACE
IN 4 POSITIONS.

UNA GELATERIA DA BANCO

Ideale per l'esposizione e la conservazione di torte gelato, stecchi e ghiaccioli.

AN ICE-CREAM COUNTER,

ideal to display and to store ice-cream cakes, sticks and popsicles.



DUAL



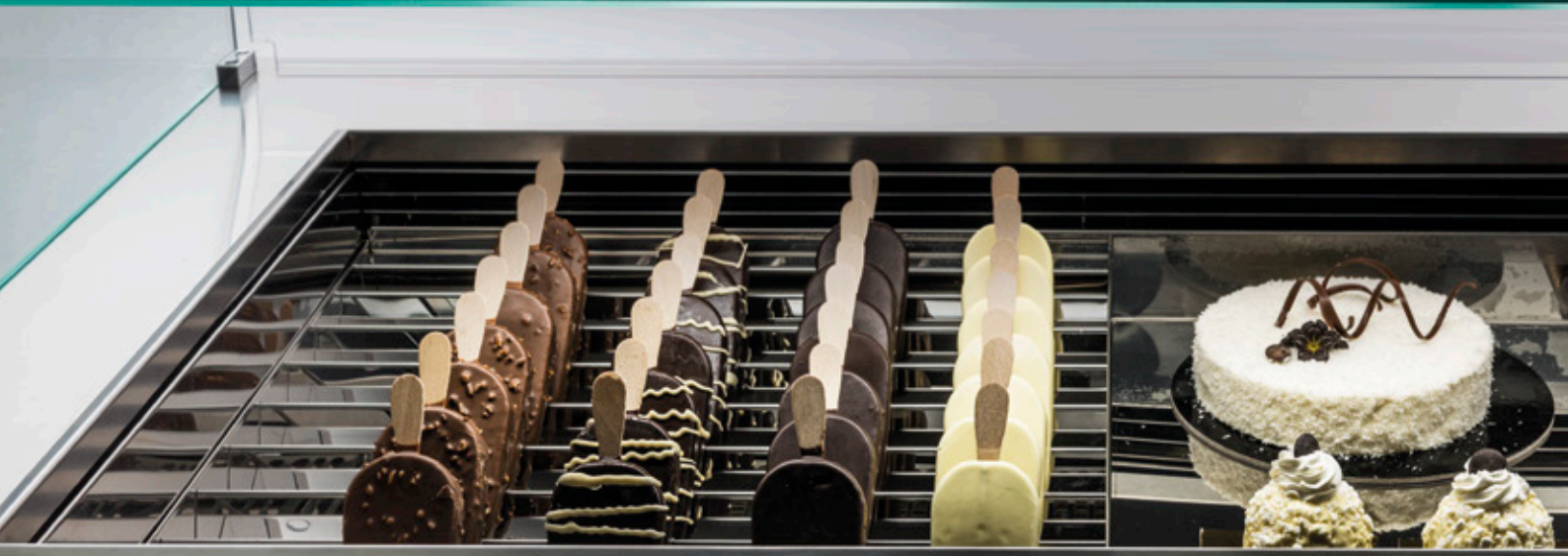

Possibilità tramite gli appositi accessori di esporre nella stessa vasca torte, gelato monoporzioni, ghiaccioli e stecchi.

Thanks to the specific accessories, you can display in the same tub ice-cream cakes, single-portion cakes, sticks and popsicles.

Vasca DUAL completa di kit portastecchi e teca in vetro con illuminazione led e scorrevoli posteriori.

DUAL tub complete with stickholder kit, and glass canopy with led lighting and rear sliding doors.

DUAL



I PIANETTI SONO REGOLABILI
E INDIPENDENTI. PERMETTONO
UN'ESPOSIZIONE DEL PRODOTTO A
DIVERSE ALTEZZE.

THE SHELVES ARE ADJUSTABLE AND
INDEPENDENT. THEY ALLOW TO DISPLAY
THE PRODUCT AT DIFFERENT HEIGHTS.



IL BANCO SI TRASFORMA IN UNA GELATERIA.

Possibilità di inserire vaschette in acciaio inox di mm.265x162.

THE COUNTER TURNS INTO AN ICE-CREAM UNIT.

Possibility to put stainless steel trays mm.265x162.



DUAL





La vasca gelateria DUAL
permette di allestire un banco
con tutte le funzioni perfettamente
allineate: **gelateria, pasticceria, pralineria
e gastronomia.**

DUAL ice-cream tub allows
to set up a counter with all functions,
perfectly aligned: **ice-cream, pastry,
chocolates and gastronomy.**



DUAL



MISURE COMPONENTI

DIMENSIONS, MODULARITY

SEZIONE VASCHE DUAL - TN

DUAL TUBS SECTION - TN (normal temperature)

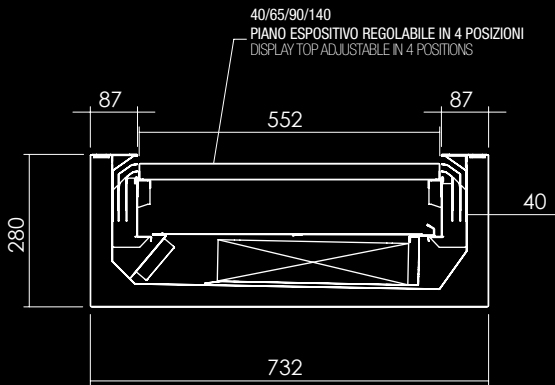

FREDDO VENTILATO
COLD VENTILATED

PRALINERIA
CHOCOLATES

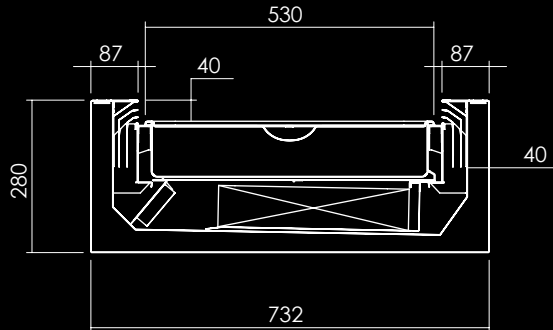

FREDDO VENTILATO CON VASCHE GN
COLD VENTILATED WITH GN TRAYS

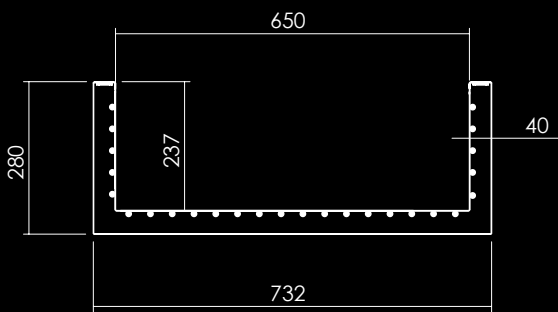

FREDDO STATICO
COLD STATIC

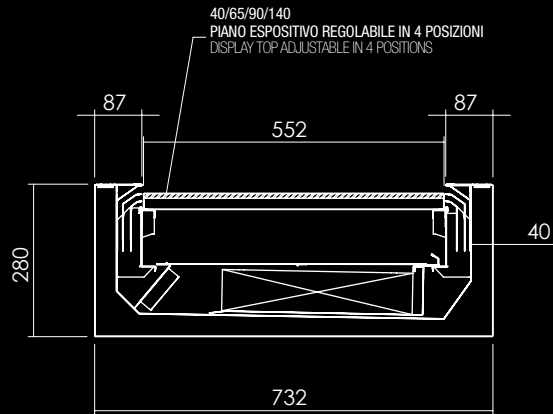

FREDDO VENTILATO / CALDO SECCO
COLD VENTILATED / DRY HOT

SEZIONE VASCHE DUAL - BT

DUAL TUBS PLAN - BT (low temperature)

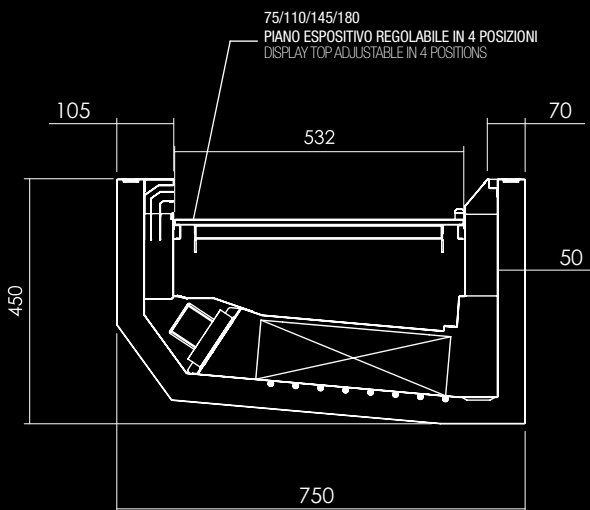

FREDDO VENTILATO BT
COLD VENTILATED BT

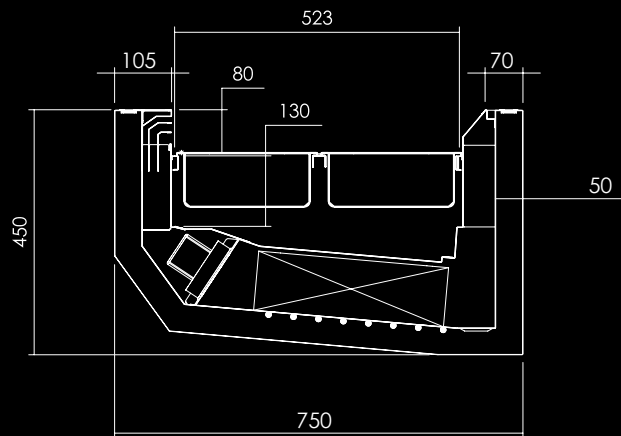

FREDDO VENTILATO BT CON VASCHE GELATO
COLD VENTILATED BT WITH ICE CREAM TANS

PIANTA VASCHE DUAL - TN

DUAL TUBS PLAN – TN (normal temperature)

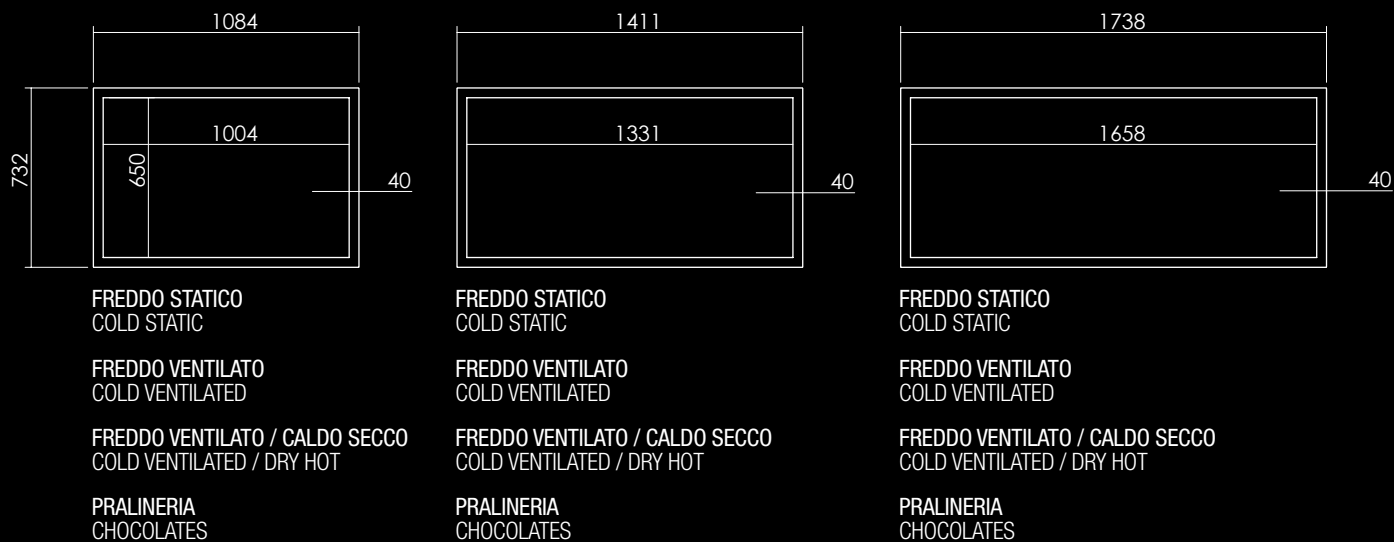

PIANTA VASCHE DUAL - BT

DUAL TUBS PLAN – BT (low temperature)

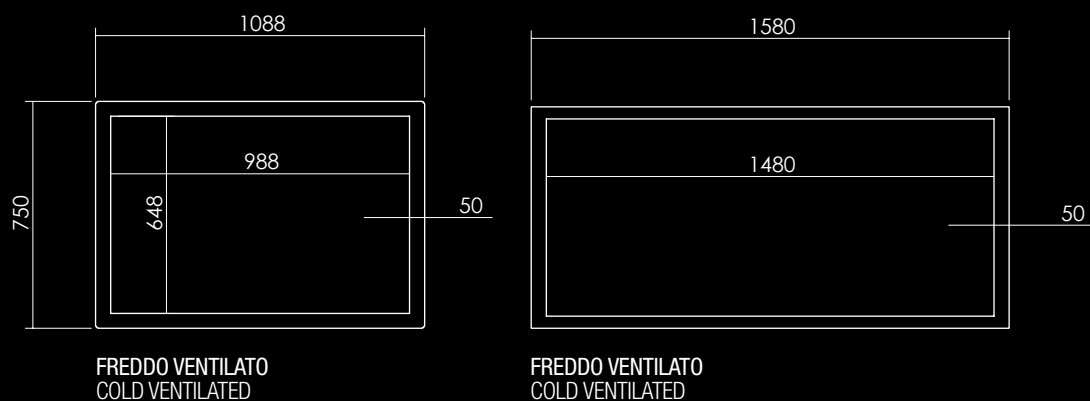



DROP IN

NEA
SUPERFICI
ESPOSITIVE SENZA
INTERRUZIONI

NEA DISPLAY SURFACES
WITHOUT INTERRUPTION

NEA È SOPRATTUTTO UNA SOLUZIONE
ECLETTICA E VERSATILE. RAPPRESENTA IL
SUPPORTO IDEALE PER UNA GRANDE VARIETÀ
DI PRODOTTI ALIMENTARI: PASTICCERIA,
PRALINERIA, MA ANCHE PANE, PIZZA,
FINO AD ARRIVARE AL GELATO.

ABOVE ALL, NEA IS AN ECLECTIC AND VERSATILE
STRUCTURE. IT'S AN IDEAL SUPPORT FOR A GREAT
VARIETY OF FOODS: PASTRY, CHOCOLATE, BREAD,
PIZZA AND ICE CREAM TOO.

OTTIMIZZAZIONE DEGLI SPAZI:
L'ALTEZZA DELLA VASCA PERMETTE
L'INSERIMENTO DELLA CELLA DI RISERVA.

SPACE OPTIMIZATION:
THE HEIGHT OF THE TUB ALLOWS
TO INSERT THE REFRIGERATED
STORAGE UNIT.

TECNOLOGIA E MODULARITA'.
RAFFINATEZZA TECNICA AL SERVIZIO
DI ARCHITETTI E ARREDATORI.

NEA

TECHNOLOGY AND MODULARITY:
TECHNICAL REFINEMENT SERVING
ARCHITECTS AND INTERIOR DESIGNERS.



L'apertura
con pistoni a gas
permette di alzare
il corpo refrigerante e
il piano espositivo,
semplificando le operazioni
di manutenzione e pulizia.

The opening by gas pistons
allows to lift the refrigerant
section and the display
surface, for maintenance
and tub cleaning.

La perfetta canalizzazione tra più moduli crea un'unica superficie espositiva senza interruzioni e genera capienza e praticità.

Perfectly canalized modules create a single continuous display surface, bringing capacity and convenience.



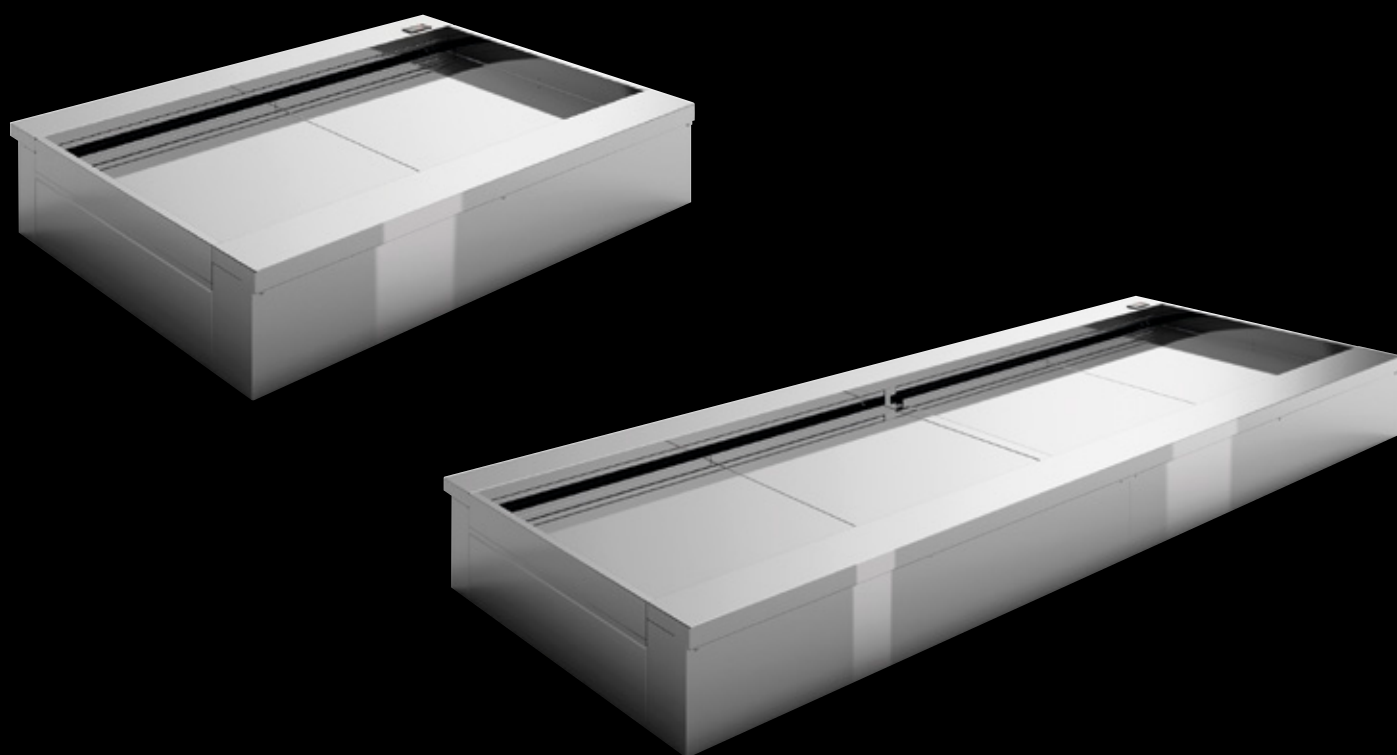

LE NOSTRE VASCHE SONO STUDIATE
PER ADATTARSI AD OGNI TIPO DI
MATERIALE, PERFETTE PER QUALSIASI
TIPO DI RIVESTIMENTO, PER OTTENERE
SEMPRE IL RISULTATO ESTETICO
DESIDERATO.

OUR TUBS ARE DESIGNED
TO FIT ANY TYPE OF MATERIAL,
PERFECT FOR ANY TYPE OF FINISHING
TO CONSISTENTLY ACHIEVE
THE DESIRED AESTHETIC RESULT.

MISURE COMPONENTI

DIMENSIONS, MODULARITY

SEZIONE VASCA NEA NEA TUB SECTION

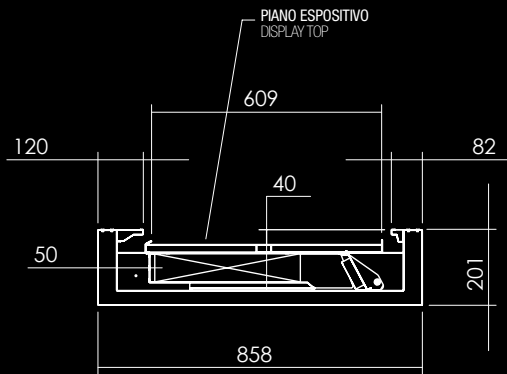

PIANTA VASCHE NEA

NEA TUBS PLAN

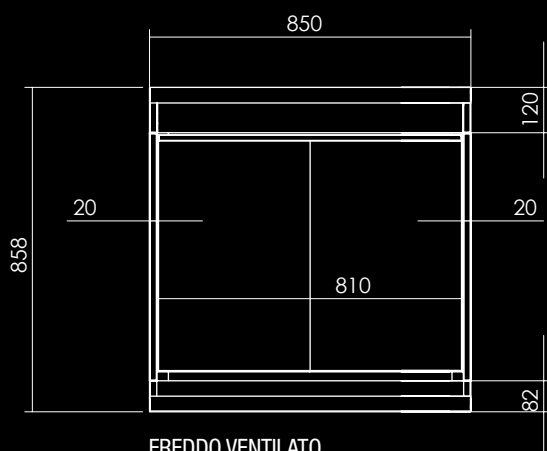

FREDDO VENTILATO
COLD VENTILATED

FREDDO VENTILATO / CALDO SECCO
COLD VENTILATED / DRY HOT

PRALINERIA
CHOCOLATES

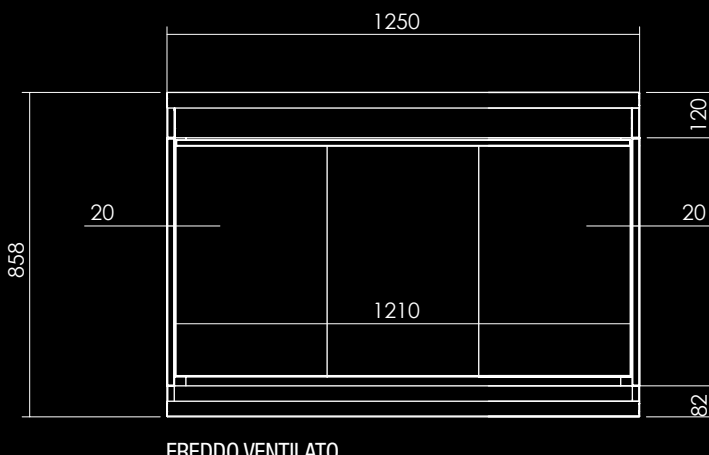

FREDDO VENTILATO
COLD VENTILATED

FREDDO VENTILATO / CALDO SECCO
COLD VENTILATED / DRY HOT

PRALINERIA
CHOCOLATES

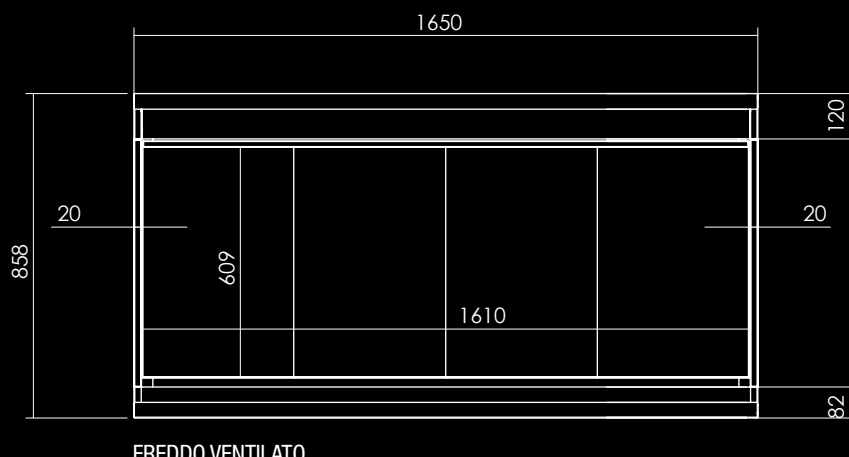

FREDDO VENTILATO
COLD VENTILATED

FREDDO VENTILATO / CALDO SECCO
COLD VENTILATED / DRY HOT

PRALINERIA
CHOCOLATES

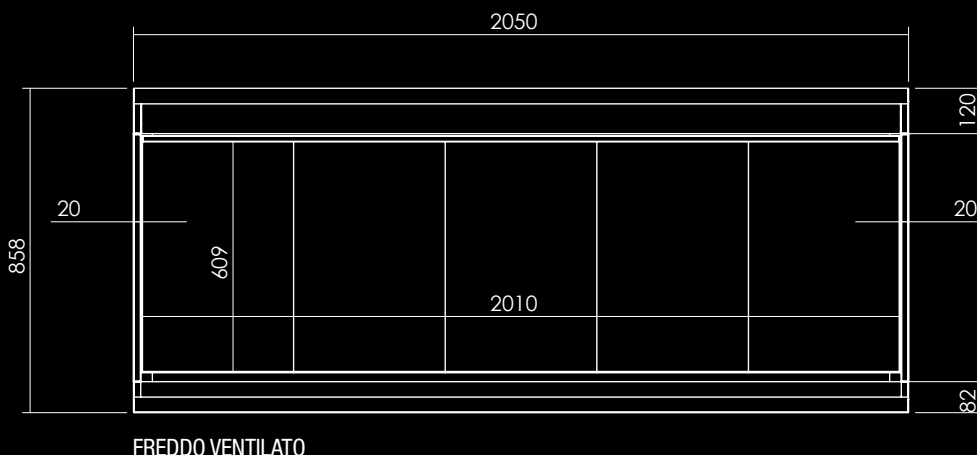

FREDDO VENTILATO
COLD VENTILATED

FREDDO VENTILATO / CALDO SECCO
COLD VENTILATED / DRY HOT

NB. Le misure rappresentate indicano le dimensioni della vasca, non sono utilizzabili per realizzare i fori sui top.

NOTE. The described sizes represent the tub's dimensions, they are not valid for the holes to be made on the working top.



DROP IN

P60 - P80
PER OGNI
MOMENTO
DELLA
GIORNATA

P60-P80
FOR EVERY MOMENT
OF THE DAY

TECNOLOGIA E MODULARITÀ
PER IMMAGINARE QUALSIASI
TIPOLOGIA DI LOCALE.

TECHNOLOGY AND MODULARITY
TO IMAGINE ANY KIND OF PLACE.



FREDDO STATICO.
VASCA P60 (P600 L715)
CON VASCA GN 2/1 FORATA
PER GHIACCIO.

COLD STATIC.
TUB P60 (P600 L715)
WITH GN 2/1 TRAY WITH HOLES
FOR ICE.

P60 - P80



Esempi di configurazione
vasca statica P60 con vasche GN.

Examples of configuration
for static tub P60 with GN trays.



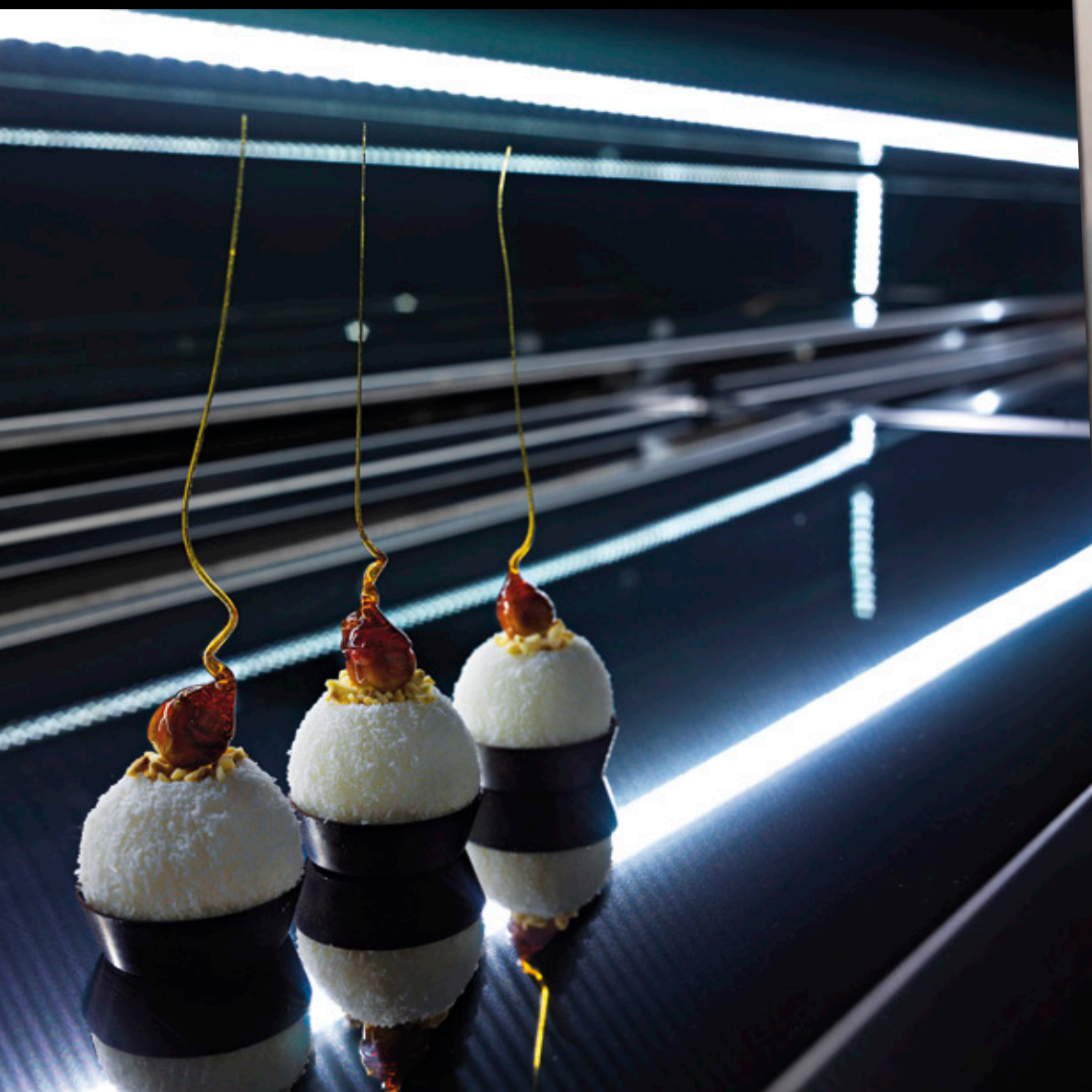

FREDDO VENTILATO, ESPOSIZIONE
IDEALE PER UNA TEMPERATURA IDEALE.
LA VASCA VENTILATA CONSERVA
IL FRESCO COSTANTE ED EQUILIBRATO.
IL PIANO RIBASSATO DI POCHI CENTIMETRI
OFFRE UNA MIGLIORE VISIBILITÀ.

COLD VENTILATED, IDEAL DISPLAY
FOR AN IDEAL TEMPERATURE.
THE VENTILATED TUB KEEPS A CONSTANT
AND BALANCED COOL. THE TOP SURFACE,
A FEW CENTIMETERS LOWERED,
OFFERS A BETTER VISIBILITY.

P60 - P80

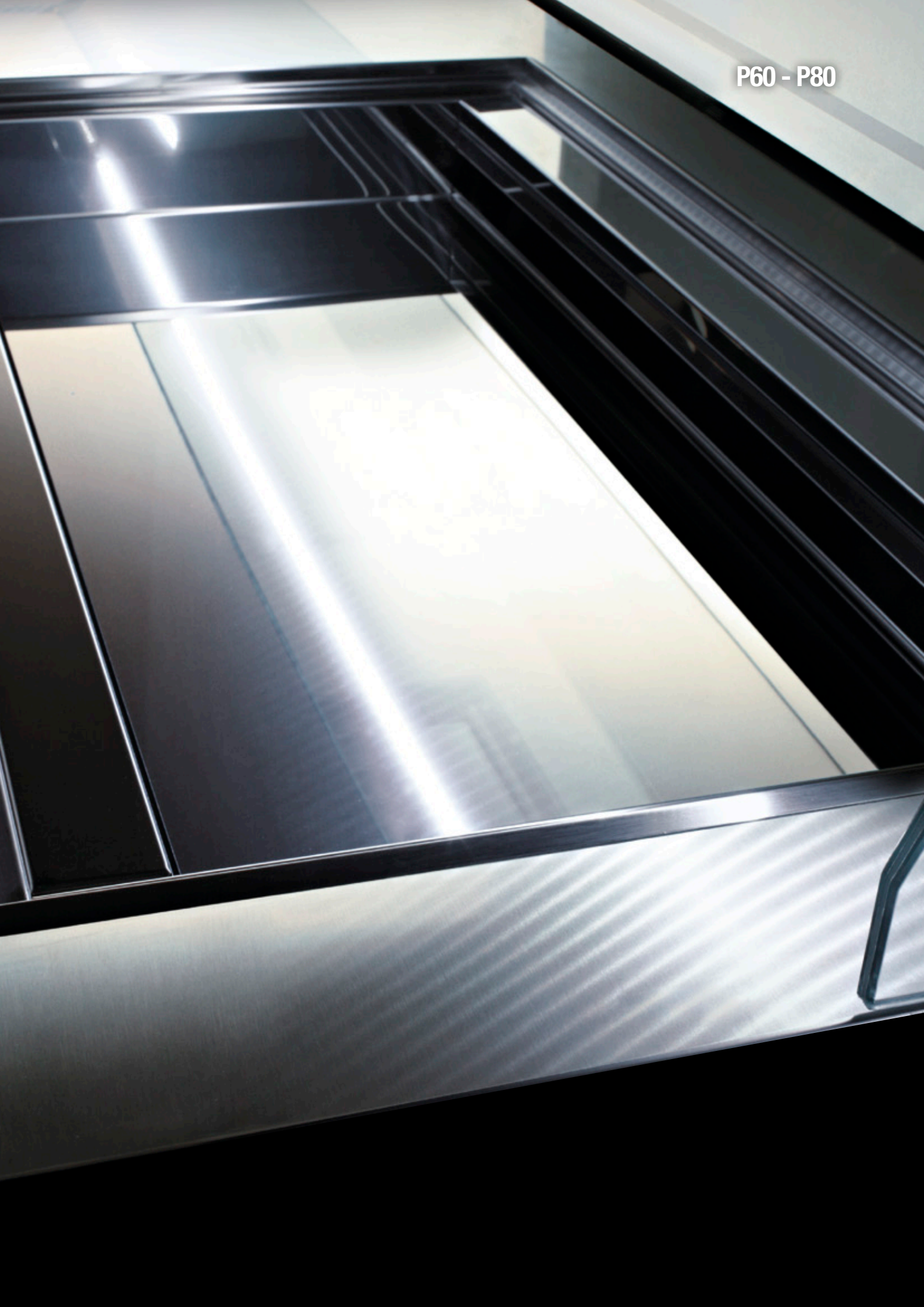



P60 - P80

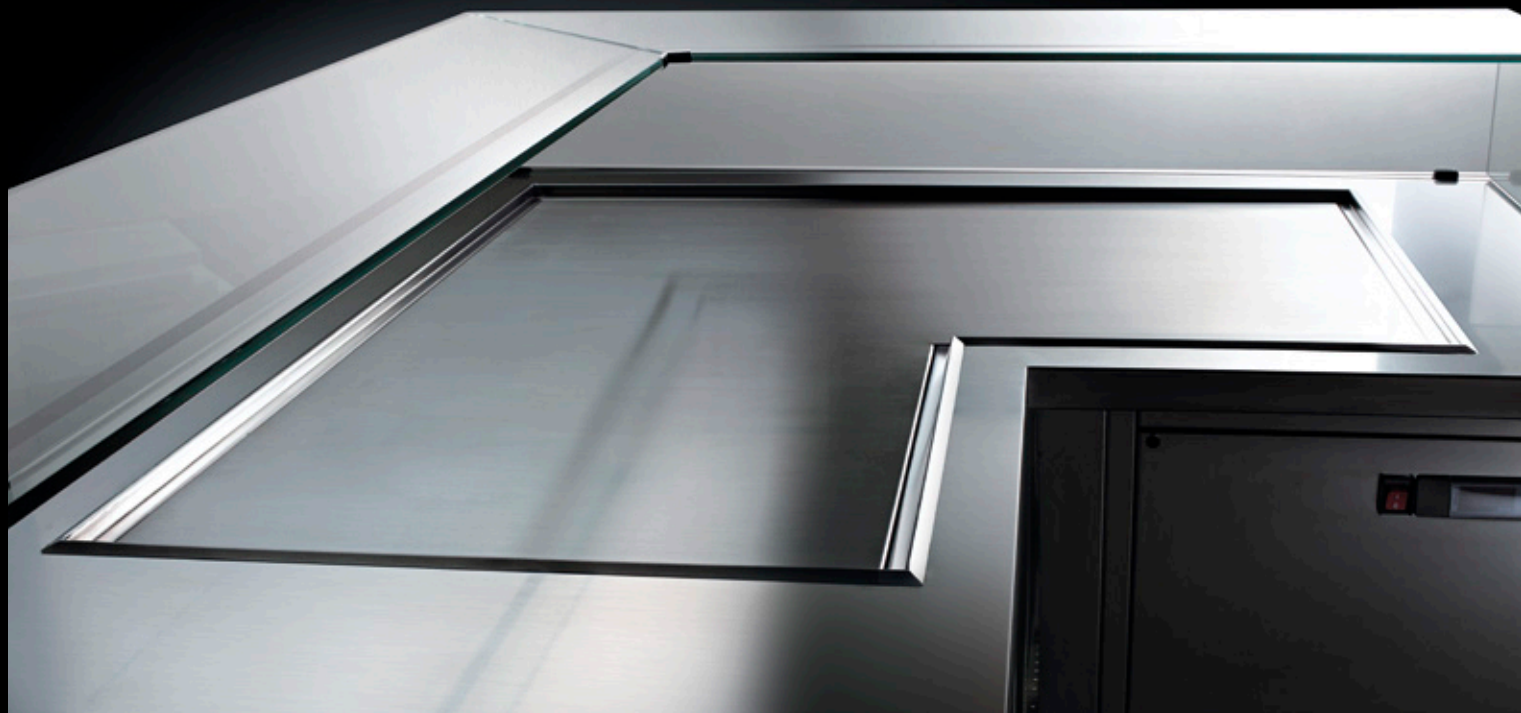

PIASTRA REFRIGERATA
O RISCALDATA IN ACCIAIO
CHE OFFRE UNA PERFETTA
ESPOSIZIONE DEI PRODOTTI.

REFRIGERATED OR HEATED
STEEL PLATE WHICH OFFERS
A PERFECT DISPLAY OF
THE PRODUCTS.



Piastra caldo secco in vetro piroolitico nero
per esaltare il prodotto esposto.

Dry-hot plate in black glass to enhance
the displayed product.

MISURE COMPONENTI

DIMENSIONS, MODULARITY

SEZIONE VASCHE P60 - P80

P60 - P80 TUBS SECTION

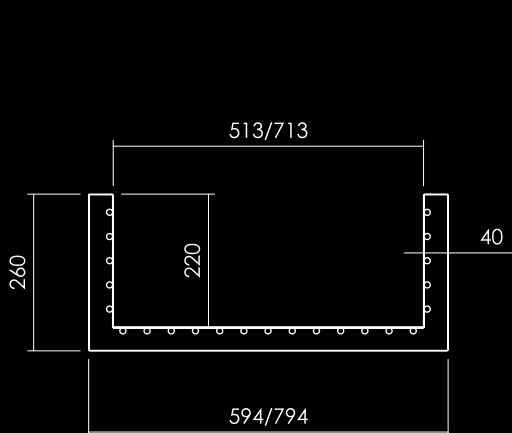

FREDDO STATICO
COLD STATIC

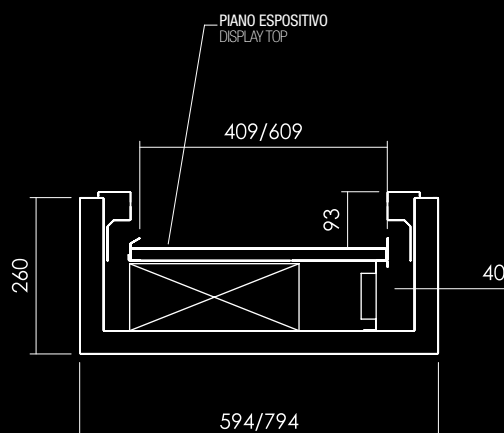

FREDDO VENTILATO
COLD VENTILATED

FREDDO VENTILATO / CALDO SECCO
COLD VENTILATED / DRY HOT

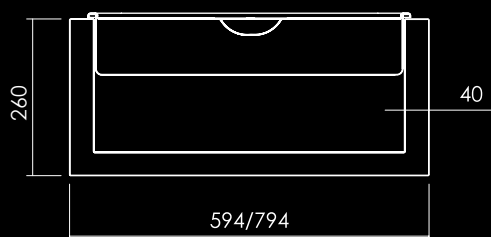

BAGNO MARIA
BAIN-MARIE

SEZIONE PIANI P60 - P80

P60 - P80 TOPS SECTION

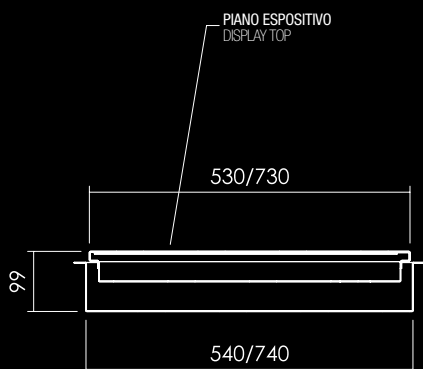

FREDDO STATICO A CONTATTO
COLD STATIC BY CONTACT

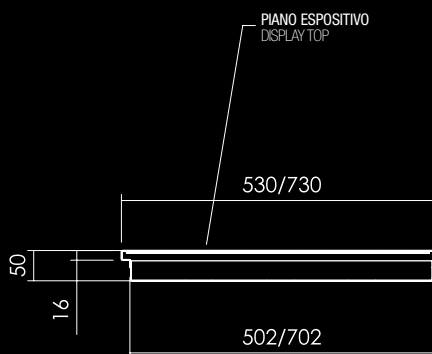

CALDO SECCO
DRY HOT

PIANTA VASCHE P60

P60 TUBS PLAN

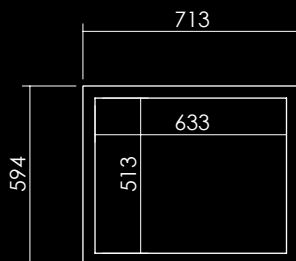

FREDDO STATICO
COLD STATIC

FREDDO VENTILATO
COLD VENTILATED

FREDDO VENTILATO / CALDO SECCO
COLD VENTILATED / DRY HOT

BAGNO MARIA
BAIN-MARIE



FREDDO STATICO
COLD STATIC

FREDDO VENTILATO
COLD VENTILATED

FREDDO VENTILATO / CALDO SECCO
COLD VENTILATED / DRY HOT

BAGNO MARIA
BAIN-MARIE

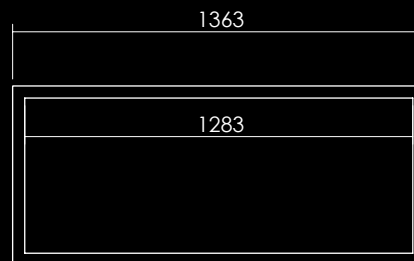

FREDDO STATICO
COLD STATIC

FREDDO VENTILATO
COLD VENTILATED

FREDDO VENTILATO / CALDO SECCO
COLD VENTILATED / DRY HOT

BAGNO MARIA
BAIN-MARIE



FREDDO STATICO
COLD STATIC

FREDDO VENTILATO
COLD VENTILATED

FREDDO VENTILATO / CALDO SECCO
COLD VENTILATED / DRY HOT

BAGNO MARIA
BAIN-MARIE

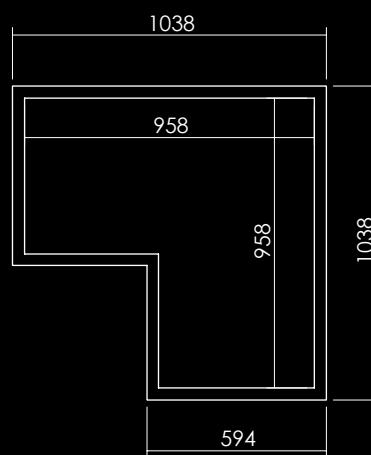

FREDDO STATICO
COLD STATIC

MISURE COMPONENTI

DIMENSIONS, MODULARITY

PIANTA VASCHE P80

P60 - P80 TUBS PLAN

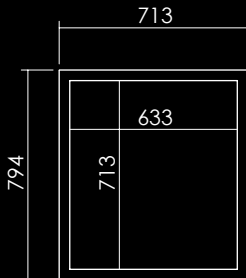

FREDDO STATICO
COLD STATIC

FREDDO VENTILATO
COLD VENTILATED

FREDDO VENTILATO / CALDO SECCO
COLD VENTILATED / DRY HOT

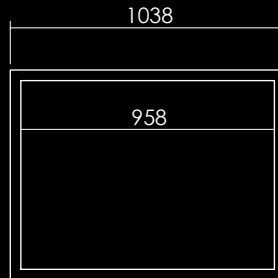

FREDDO STATICO
COLD STATIC

FREDDO VENTILATO
COLD VENTILATED

FREDDO VENTILATO / CALDO SECCO
COLD VENTILATED / DRY HOT



FREDDO STATICO
COLD STATIC

FREDDO VENTILATO
COLD VENTILATED

FREDDO VENTILATO / CALDO SECCO
COLD VENTILATED / DRY HOT



FREDDO STATICO
COLD STATIC

FREDDO VENTILATO
COLD VENTILATED

FREDDO VENTILATO / CALDO SECCO
COLD VENTILATED / DRY HOT

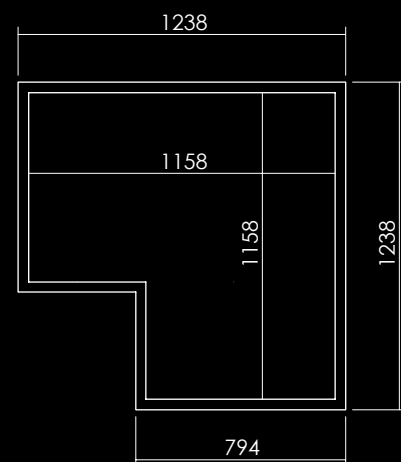

FREDDO STATICO
COLD STATIC

PIANTA PIANI A CONTATTO P60 - P80

P60 - P80 TOPS BY CONTACT PLAN



FREDDO STATICO A CONTATTO
COLD STATIC BY CONTACT

CALDO SECCO
DRY HOT

CALDO SECCO IN VETRO
DRY HOT IN GLASS

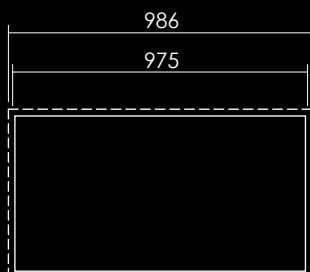

FREDDO STATICO A CONTATTO
COLD STATIC BY CONTACT

CALDO SECCO
DRY HOT

CALDO SECCO IN VETRO
DRY HOT IN GLASS



FREDDO STATICO A CONTATTO
COLD STATIC BY CONTACT

CALDO SECCO
DRY HOT

CALDO SECCO IN VETRO
DRY HOT IN GLASS

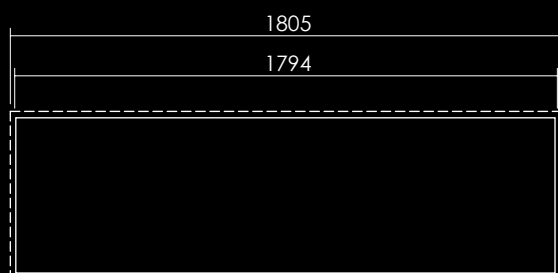

FREDDO STATICO A CONTATTO
COLD STATIC BY CONTACT

CALDO SECCO
DRY HOT

CALDO SECCO IN VETRO
DRY HOT IN GLASS

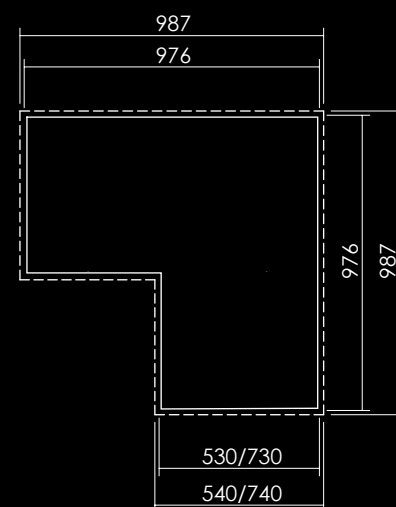

FREDDO STATICO A CONTATTO
COLD STATIC BY CONTACT

CALDO SECCO
DRY HOT

————— MISURA PIANO ESPOSITIVO
DISPLAY TOP SIZE

- - - - - MISURA INGOMBRO STRUTTURA SOTTO PIANO (SOLO FUNZIONE FREDDO)
SIZE OF DRIPTRAY UNDER THE PLAN (FOR COLD VERSION)

NB. Le misure rappresentate indicano le dimensioni della vasca, non sono utilizzabili per realizzare i fori sui top.
NOTE. The described sizes represent the tub's dimensions, they are not valid for the holes to be made on the working top.



P60 BT

Vasche a bassa temperatura.
Per contenere ed esporre in modo
innovativo diverse tipologie di prodotto.

Tub with low temperature.
To store and display different kinds
of products in an innovative way.



VASCA BT: IDEALE PER L'ESPOSIZIONE E
LA CONSERVAZIONE DI TORTE GELATO,
STECCHI E GHIACCIOLI.

BT TUB: IDEAL TO DISPLAY AND
STORE ICE-CREAM CAKES, STICKS
AND POPSICLES.



P60 COCKTAIL TUTTO IL NECESSARIO
PER LA PREPARAZIONE DEL COCKTAIL
IN UNO SPAZIO PICCOLO E COMPLETO.

P60 COCKTAIL, EVERYTHING YOU NEED
TO PREPARE COCKTAILS, IN A SMALL
AND COMPLETE SPACE.



P60 COCKTAIL



Vasca cocktail: vasca coibentata per mantenimento ghiaccio, vaschette GN 1/9 per fruttini e guarnizioni. disponibile con e senza livello

Cocktail tub: insulated tub for ice conservation, GN trays 1/9 for sauces, cream and toppings. Available with or without sink

MISURE COMPONENTI

DIMENSIONS, MODULARITY

SEZIONE VASCHE P60 - COCKTAIL

P60 TUBS SECTION - COCKTAIL

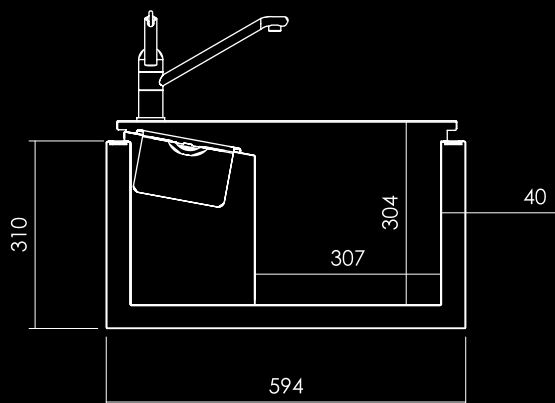

SEZIONE FREDDO VENTILATA P60 - BT

P60 COLD VENTILATED - BT (low temperature) SECTION

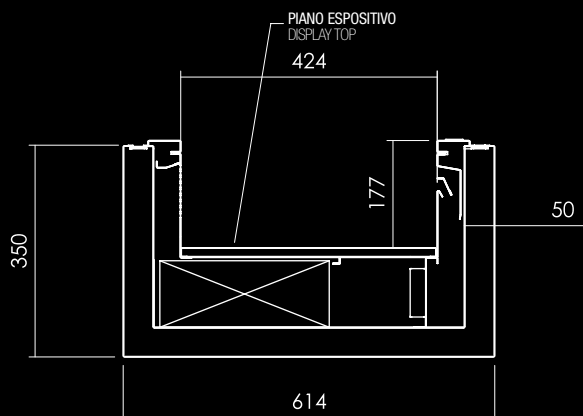

P60 BT COCKTAIL

PIANTA VASCHE P60 - COCKTAIL

P60 TUBS PLAN - COCKTAIL

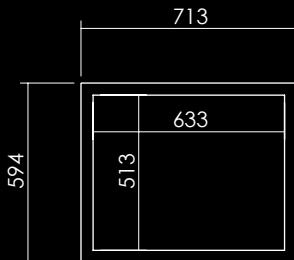

COCKTAIL
COCKTAIL



COCKTAIL
COCKTAIL



COCKTAIL
COCKTAIL

PIANTA FREDDO VENTILATA P60 - BT

P60 COLD VENTILATED - BT (low temperature) PLAN

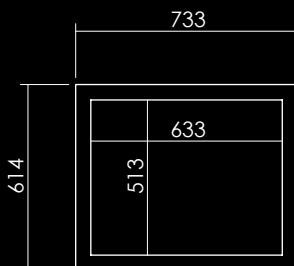

FREDDO VENTILATO BT
COLD VENTILATED BT



FREDDO VENTILATO BT
COLD VENTILATED BT

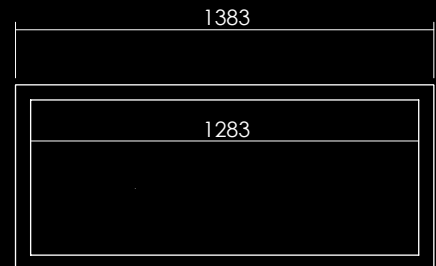

FREDDO VENTILATO BT
COLD VENTILATED BT

NB. Le misure rappresentate indicano le dimensioni della vasca, non sono utilizzabili per realizzare i fori sui top.
NOTE. The described sizes represent the tub's dimensions, they are not valid for the holes to be made on the working top.



DROP IN

**VASCHE
FRUTTINI
CALDE,
FREDDÉ
E NEUTRE**

"FRUTTINI" TUBS, HOT,
COLD AND NEUTRAL

UNA BELLA ESPOSIZIONE RENDE OGNI PRODOTTO PIU' INVITANTE; LA PERFETTA REFRIGERAZIONE MANTIENE MACEDONIE E CENTRIFUGHE, CREME E YOGURT, VERDURE E INSALATE ALLA GIUSTA TEMPERATURA, IMPEDENDO L'OSSIDAZIONE E PRESERVANDONE IL GUSTO E LA BELLEZZA.

A NICE DISPLAY MAKES EACH PRODUCT MORE ATTRACTIVE; PERFECT REFRIGERATION KEEPS FRUIT AND SMOOTHIES, CREAMS AND YOGURT, VEGETABLES AND SALADS, AT THE RIGHT TEMPERATURE, PREVENTING OXIDATION AND PRESERVING THEIR TASTE AND BEAUTY.



NEUTRA
NEUTRAL

REFRIGERATA
REFRIGERATED

CALDA
HOT

GRAZIE AL PROGETTO SARTORIALE
IL CLIENTE PUO' REALIZZARE AMBIENTI SU MISURA,
IN FUNZIONE DELLE PROPRIE ESIGENZE COMMERCIALI;
IN OGNI BANCO E' POSSIBILE DISPORRE LE VASCHE
SECONDO LE PROPRIE NECESSITA'.

THANKS TO TAILORED PROJECTS, YOUR CUSTOMERS
CAN CREATE BESPOKE PLACES, ACCORDING TO THEIR
OWN COMMERCIAL NEEDS; IN EACH COUNTER IT'S POSSIBLE
TO ARRANGE THE TRAYS ACCORDING TO ANY REQUIREMENTS.

FRUTTINI

Prelibatezze calde o fredde:
Offri sempre qualcosa di unico,
preparato e conservato al meglio.

Hot or cold deliciousness:
offer something unique, prepared
and maintained at its best.



MISURE COMPONENTI

DIMENSIONS, MODULARITY

SEZIONE VASCHE FRUTTINI

"FRUTTINI" TUBS SECTION

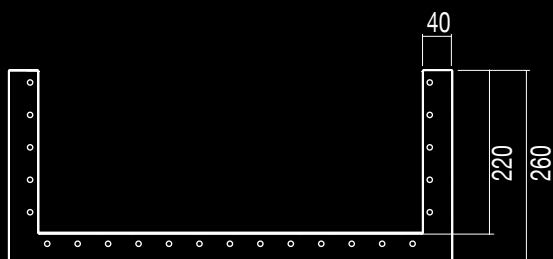

FREDDO STATICO
COLD STATIC



NEUTRO COIBENTATO CALDO SECCO
INSULATED NEUTRAL DRY HOT

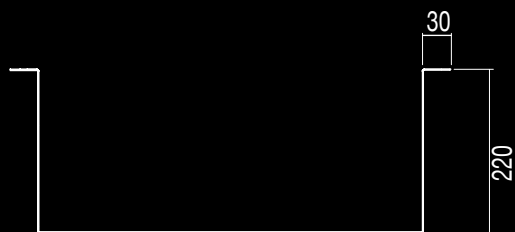

NEUTRO
NEUTRAL

PIANTA VASCHE FRUTTINI

"FRUTTINI" TUBS PLAN

FREDDO STATICO
COLD STATIC

CALDO SECCO
DRY HOT

NEUTRO
NEUTRAL

NEUTRO COIBENTATO
INSULATED NEUTRAL

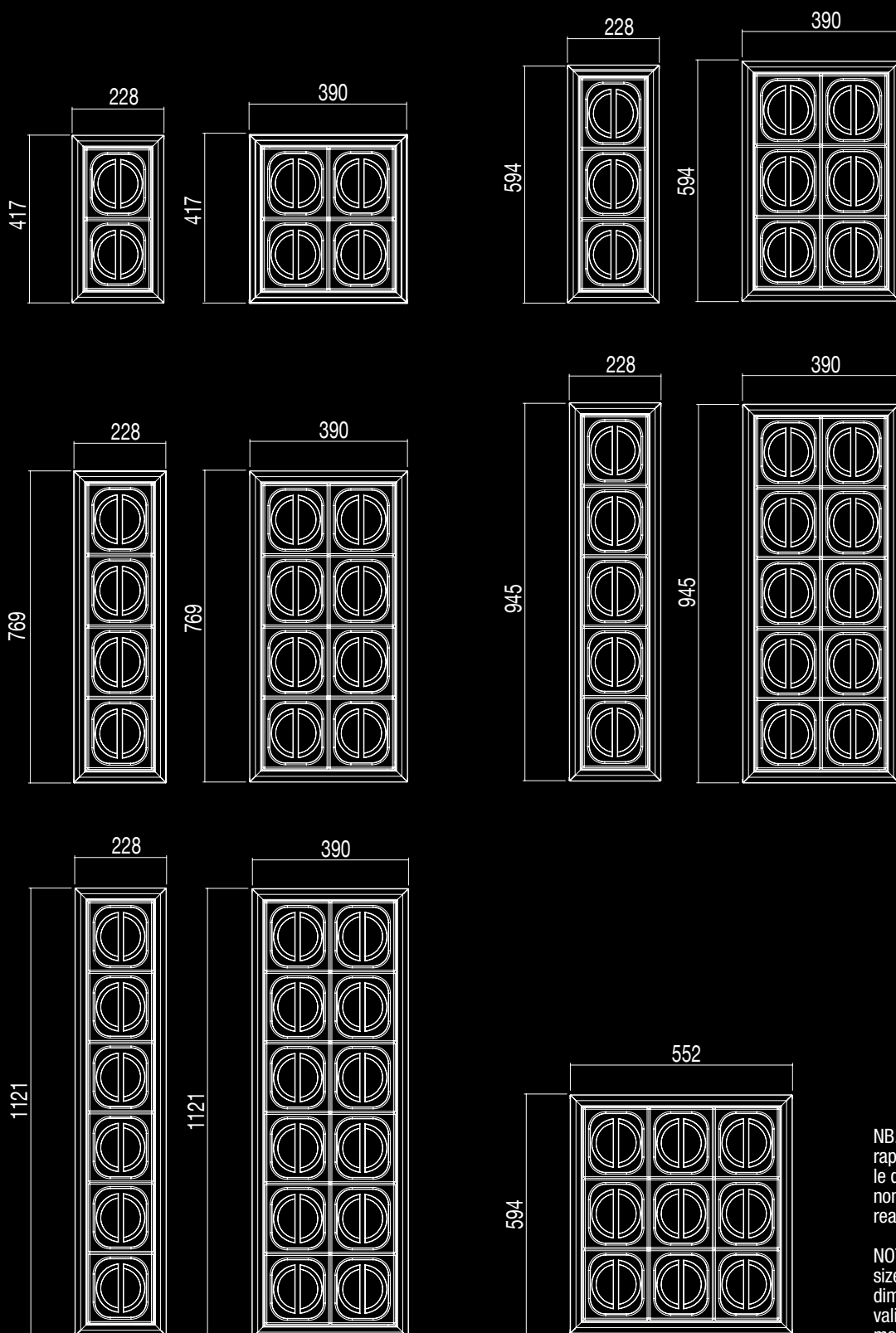

NB. Le misure rappresentate indicano le dimensioni della vasca, non sono utilizzabili per realizzare i fori sui top.

NOTE. The described sizes represent the tub's dimensions, they are not valid for the holes to be made on the working top.

HOREQUIP
QUALITY & SERVICE

www.horequip.es